



DEDAN KIMATHI UNIVERSITY OF TECHNOLOGY

University Examinations 2021/2022

FIRST YEAR FIRST SEMESTER EXAMINATION FOR THE DEGREE OF MASTER
OF SCIENCE IN MACHINE TOOL DESIGN AND MANUFACTURING

EMM 6106 MOLD PRODUCTION PLANNING & TOOLING

DATE: DECEMBER 2021

TIME: 3 HOURS

INSTRUCTIONS

1. This paper contains five questions.
 2. Answer any other four questions.
 3. All symbols have usual meaning unless otherwise stated.
-

QUESTION 1 - 25 MARKS

- (a) Injection molding is a common method for mass production and is often preferred over other processes. Explain in detail why the mold design is of critical importance. (3 Marks)
- (b) (i) Explain the main goal of cavity layout design. (1 Mark)
(ii) Placing all the cavities along a line is a simple but poor design. Clearly explain two reasons for the poor design. (4 Marks)
(ii) State two other common cavity layout designs and explain their respective main advantage. (3 Marks)
- (c) (i) The size of the mold base is determined primarily by the area required to accommodate all the cavity inserts per the designed cavity layout. Explain the conflicts that may occur leading to mold bases being sized larger than what would first be considered. (3 Marks)
(ii) Explain in detail why mold strength design should also consider both fatigue and deflection in addition to von Mises stress. (4 Marks)
- (d) Fig. Q. 1(d) shows bezel mold dimensions for compressive stress analysis. The young's modulus for the material of the mold is 205 GPa.
(i) Estimate the change in the stack height of the bezel mold when clamped with 200 metric tons of force. Assume a monolithic block in a uniform state of compression. (3 Marks)
(ii) Estimate the change in the height of the mold cavity due to the clamping of the surrounding 'A' plate with the 200 tons of force. (4 Marks)

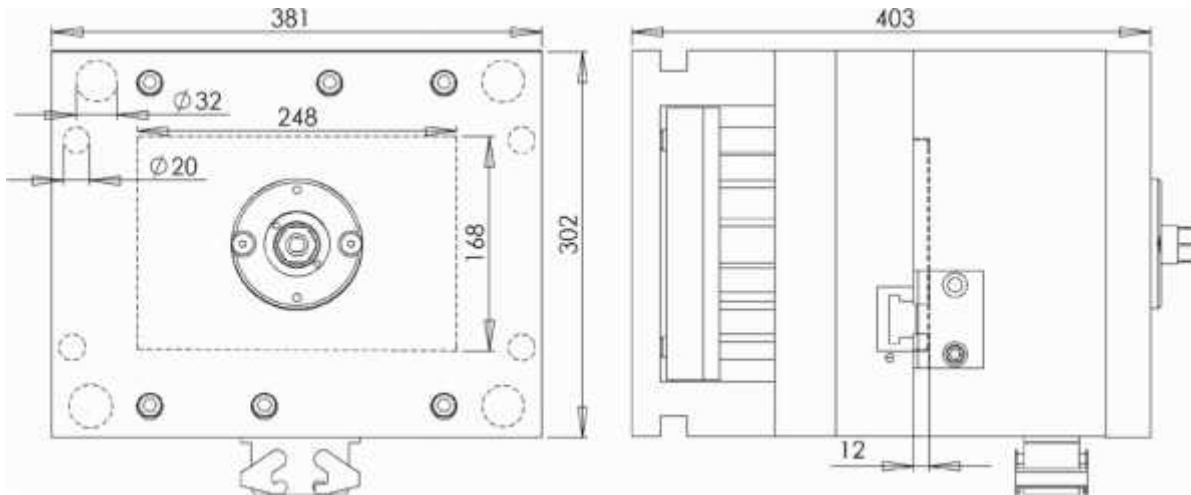

Fig. Q. 1 (d)

QUESTION 2 -25 MARKS

- (a) Every mold designer strives to minimize the molding cycle time and costs. Explain the main challenges encountering during the following molding stages. (2 Marks)
- (i) Cooling (2 Marks)
 - (ii) Ejection and reset (2 Marks)
- (b) Fig. Q. 2(b) shows a hollow section of a core insert loaded by melt pressure. Assume that the outer diameter is 60 mm, the wall thickness, h_{core} , is 10 mm, and the melt pressure is 80 MPa. It is known that cyclic fatigue is very critical issue at the number of cycles expected and the endurance limit is only 140 MPa. (2 Marks)
- (i) Determine compressive hoop stress in the core insert. (2 Marks)
 - (ii) Also recommend a maximum inner diameter of the core insert. (2 Marks)

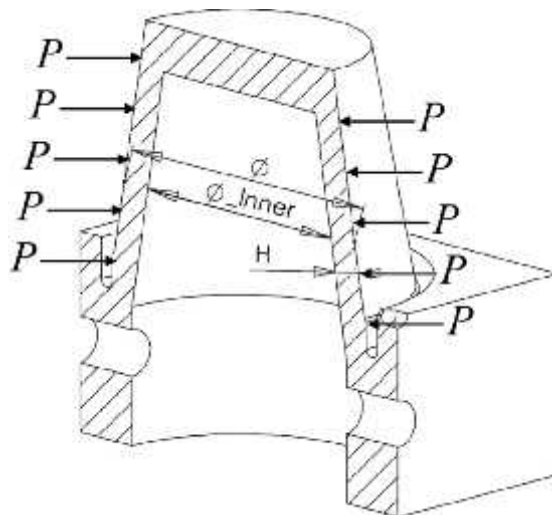

Fig. Q. 2(b)

- (c) (i) Another consideration with slender cores, in (b) above, is excessive deflection. Explain this phenomenon and main causes. (4 Marks)
- (ii) With the aid of a sketch, explain how interlocking of slender core pins reduces the deflection. (5 Marks)

- (iii) Explain any other three core bending remedies that can be considered when interlocking is not possible. (3 Marks)
- (d) Fig Q. 2(d) shows two feed system layouts for making a cup and a lid.
- (i) Explain the main purpose of such feed system. (1 Mark)
- (ii) Give a molding setup where each system suitably applied. (2 Marks)
- (iii) Explain one advantage and one disadvantage of the second system over the first one. (2 Marks)



Fig. Q. 2(d)

QUESTION 3 - 25 MARKS

- (a) In a hot runner system, the feed system is encased in a heated channel. Give any six needs of a cold runner system that may not need to be considered in hot runner system. (3 Marks)
- (b) (i) Explain why gates may interfere with part aesthetics. Further, explain three ways normally employed to reduce the defect. (4 Marks)
- (ii) Explain how too small and too large gates affect the volumetric shrinkage of material in the cavities. (4 Marks)
- (c) (i) With the aid of sketches, differentiate between the sprue gate and the pin-point gate. (4 Marks)
- (ii) With the aid of sketches, show the edge gate and its nomenclature. (3 Marks)
- (iii) Explain two main advantages of the edge gate. (2 Marks)
- (d) (i) The volumetric flow rate at the nozzle of a molding machine 125 cc/s. Calculate the shear rate through two edge gates into the cavity of a bezel mold. The thickness and width of the edge gate are 0.75 mm and 6.0 mm, respectively. (3 Marks)
- (ii) Comment on your answer in (i) above, and suggest any design changes. (2 Marks)

QUESTION 4 - 25 MARKS

- (a) The equations for determining pressure drops across gates can be summarized as follows.

Geometry	Newtonian	Power-law
Strip	$\Delta P = \frac{12\mu L \dot{V}}{Wh^3}$	$\Delta P = \frac{2kL}{h} \left(\frac{2 \left(2 + \frac{1}{n} \right) \dot{V}}{Wh^2} \right)^n$
Cylinder	$\Delta P = \frac{8\mu L \dot{V}}{\pi R^4}$	$\Delta P = \frac{2kL}{R} \left(\frac{3 \left(1 + \frac{1}{n} \right) \dot{V}}{\pi R^3} \right)^n$

ABS is molded at midrange processing temperatures with a volumetric flow rate at the sprue of 125 cc/s. The viscosity of ABS is 11.2 Pa.s, the constant $k = 17\,000$ and $n = 0.35$. A fan gate is to be used. The fan gate has an initial round section with diameter of 6.35 mm and ends at the cavity as a rectangular section with a width of 14 mm and a height of 0.75 mm.

- (i) Determine the pressure drop across the fan gate. Clearly explain your choice of formula. (6 Marks)
 - (ii) Comment on your answer in (i) above. (2 Marks)
- (b) (i) The primary function of the vent is to release the air in the mold that is being displaced by the highly pressurized plastic melt. If all the air in the cavity is not removed during the filling stage, explain three main defects that can result. (5 Marks)
- (ii) Explain three different locations where venting would usually be required. (3 Marks)
- (c) It is normally not accurate to estimate the air flow through each vent as the total volumetric air flow divided by the number of vents. Explain why and give a better assumption. (3 Marks)
- (d) (i) Define cooling time in molding. (1 Mark)
- (ii) Draw the temperature history of the cooling melt in the cavity (at the centerline). By showing the modulus history as well, clearly explain how the cooling time can be determined from such graphs. (5 Marks)

QUESTION 5 - 25 Marks

- (a) ABS material is processed at mid-range temperature to produce the cup and lid family mold whose total weight is 62.6 g. The specific heat capacity of the material is 2340 J/kg.°C. The melt and the ejection temperatures are 239 °C and 96.7 °C, respectively. The allowable increase in the coolant temperature is 1°C.
- (i) Determine the power required to cool the cup and lid family mold in 20 s. (3 Marks)
 - (ii) If the cup and lid mold has 4 cooling lines (2 lines per side), determine the coolant flow rate in each line if the coolant is water. (2 Marks)

- (iii) Determine the upper limit on the diameter of the cooling line. (3 Marks)
 - (iv) Determine the actual diameter of the cooling line. Assume that the cooling lines traverse the width of the mold, and each has a length of 302 mm and the allowable pressure drop is 100 kPa. (3 Marks)
- (b) (i) List any six design objectives and/or constraints in ejection system design. (3 Marks)
- (ii) With the aid of a simple sketch, illustrate the ejection force vectors and the draft angle. (3 Marks)
 - (iii) Explain why some minimum push area should be maintained in a single pin ejecting a portion of a laptop. (2 Marks)
 - (iii) Clearly explain how you will estimate the ejection force required to strip a cup (Fig. Q. 5(b)) molded from ABS off the mold core using both the concept of hoop stress and Rosato estimation. (6 Marks)

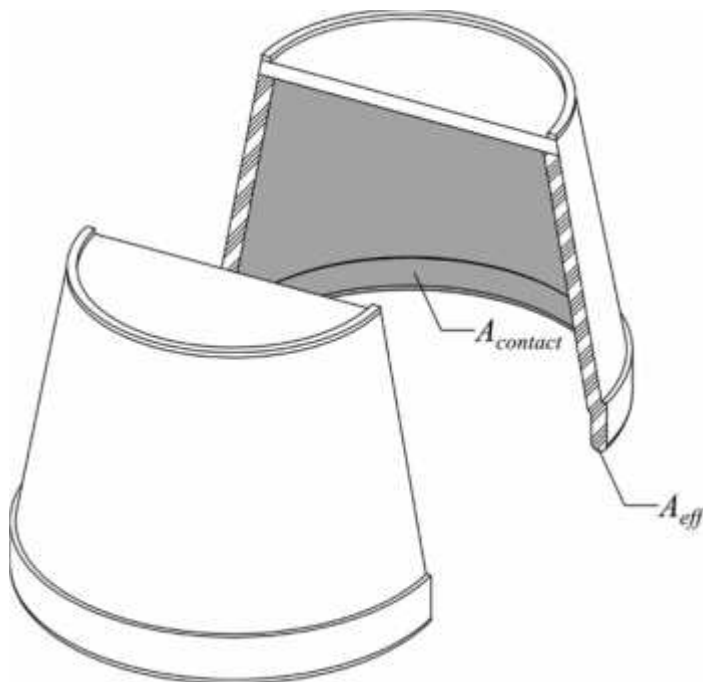

Fig. Q. 5 (b)