



DEDAN KIMATHI UNIVERSITY OF TECHNOLOGY

UNIVERSITY EXAMINATIONS – 2021/2022 ACADEMIC YEAR

FOURTH YEAR SECOND SEMESTER EXAMINATION FOR THE
DEGREE

BACHELOR OF EDUCATION IN TECHNOLOGY (ELECTRICAL &
ELECTRONIC ENGINEERING)

SPH 1222: PHYSICS II

DATE: 10TH DECEMBER, 2021

TIME: 8:30-10:30AM

INSTRUCTIONS:

*This paper consists of FIVE Questions.
Answer QUESTION ONE (COMPULSORY) and ANY OTHER TWO questions.*

QUESTION ONE.

[30 MARKS]

- a) Outline the significance of e.m.f. in electrical circuit circuits. **[3 Marks]**
- b) State Snell's Law of reflection and refraction. **[4 Marks]**
- c) With aid of well labelled diagram, discuss how X-ray is formed. **[4 Marks]**
- d) Determine the current flowing at the instant of switching a 60 W lamp on a 230V supply. The ambient temperature is 25°C. The filament temperature is 2000°C and the resistance temperature coefficient is 0.005/°C at 0°C. **[6 Marks]**
- e) A potential gradient of 3×10^6 V/m is maintained between two horizontal parallel plates 1 cm apart. An electron starts from rest at the negative plate, travels under the influence of potential gradient to the positive plate. Given the mass of electron = 9.1×10^{-31} kg and the charge on electron = 1.603×10^{-19} C. Calculate: (i) acceleration, (ii) time taken to reach the positive plate.

[4 Marks]

- f) Using capacitors of magnitude $4\mu\text{F}$ and $2\mu\text{F}$, a voltage supply of 240V , 50Hz , design a circuit with minimum possible capacitors such that the circuit equivalent capacitance is $13\mu\text{F}$. **[4 marks]**
- g) An electron moving with a velocity of 10^7 ms^{-1} enters mid-way between two horizontal plates P, Q in a direction parallel to the plates as shown in Fig. (1g) and their separation is 2cm . If a p.d. of 90V is applied between the plates, calculate the transverse deflection produced by the electric field when the electron just passes the field. Assume $e/m = 1.8 \times 10^{11}\text{ C kg}^{-1}$ **[5 Marks]**

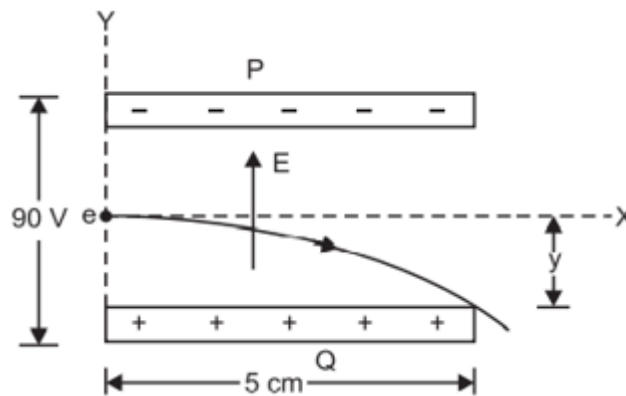

Fig. (1g)

QUESTION TWO.

[20 MARKS]

- a) Define the following terms as applied to electromagnetic circuits:
- Magnetic flux. **[1 Mark]**
 - Electrostatic flux. **[1 Mark]**
 - Coulomb's Laws of Electrostatics. **[1 Mark]**
- b) Use correct diagrams to explain the size of a magnified image. **[5 Marks]**
- c) Six resistors are connected as shown in **Fig. (1c)** below. If a battery having an e.m.f. of 24 V and internal resistance of $1\ \Omega$ is connected to the terminals A and B, Calculate the p.d. across $8\ \Omega$ and $4\ \Omega$ resistors. **[6 marks]**

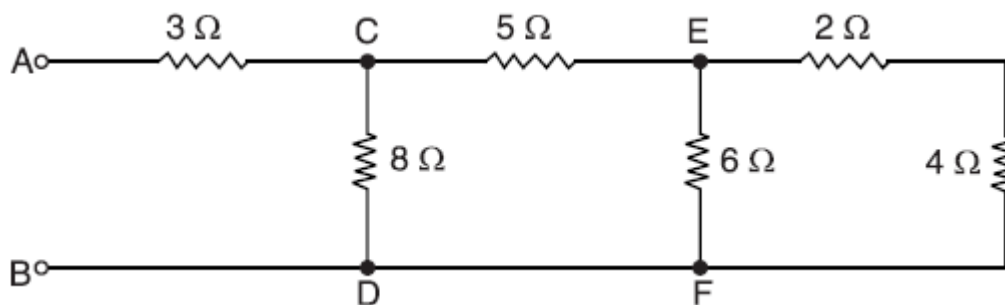

Fig. (1c).

- d) Consider the circuit with the following parameter value, $v = 8e^{-t}$ V and $i = 20e^{-t}$ A, for $t \geq 0$. Find the power absorbed and the energy supplied by the element over the first second of operation. Assume that v and i are zero for $t > 0$. **[6 Marks]**

QUESTION THREE.

[20 MARKS]

- a) Determine the value of the fixed resistors with the following coding: **[3 Marks]**
- i. Green Yellow Red
 - ii. 4R7G
 - iii. 9K34F
- b) Differentiate a loop from a mesh and also highlight their similarities as applied to electrical circuits. A small sphere is given a charge of $+20\mu\text{C}$ and a second sphere of equal diameter is given a charge of $-5\mu\text{C}$. The two spheres are allowed to touch each other and are then spaced 10 cm apart. What force exists between them? Assume air as the medium. **[4 Marks]**
- c) With the aid of a diagram discuss how light travels in a prism. **[5 marks]**
- d) Clearly distinguish between nuclear fission and nuclear fusion. **[6 Marks]**
- e) State any two uses of nuclear reaction in medicine. **[2 Marks]**

QUESTION FOUR.

[20 MARKS]

- a) A charged oil drop remains stationary when situated between two parallel plates 25mm apart. A p.d. of 1000V is applied to the plates. If the mass of the drop is 5×10^{-15} kg, determine the charge on the drop. **[6 Marks]**
- b) State Ampere's Law and use correct diagrams to illustrate how the integral of:
- i. $\oint H$ for a closed contour is zero. **[2 Marks]**
 - ii. $\oint H$ for a closed loop is equal to the current traversing the surface of the contour. **[2 Marks]**
 - iii. Explain the reason for these differences in both i) and ii). **[4 Marks]**
- c) With the aid of an appropriate example discuss Alpha radiation. **[6 Marks]**

QUESTION FIVE.

[20 MARKS]

- a) Draw well labelled diagrams to highlight the differences between a solenoid and a Horse shoe electromagnet. **[4 Marks]**
- b) Discuss the dual nature of light. **[4 Marks]**
- c) Discuss the following
 - i. Transmutation. **[3 Marks]**
 - ii. Half-life. **[3 Marks]**
- d) A single core cable for use on 11 kV, 50 Hz system has conductor area of 0.645 cm² and internal diameter of sheath is 2.18 cm. The permittivity of the dielectric used in the cable is 3.5. Determine (i) the maximum electrostatic stress in the cable (ii) minimum electrostatic stress in the cable (iii) capacitance of the cable per km length. **[6 Marks]**

.....**THE END**.....